

XTAR[®]

DS1

Magnetic Slide Switch Diving Flashlight

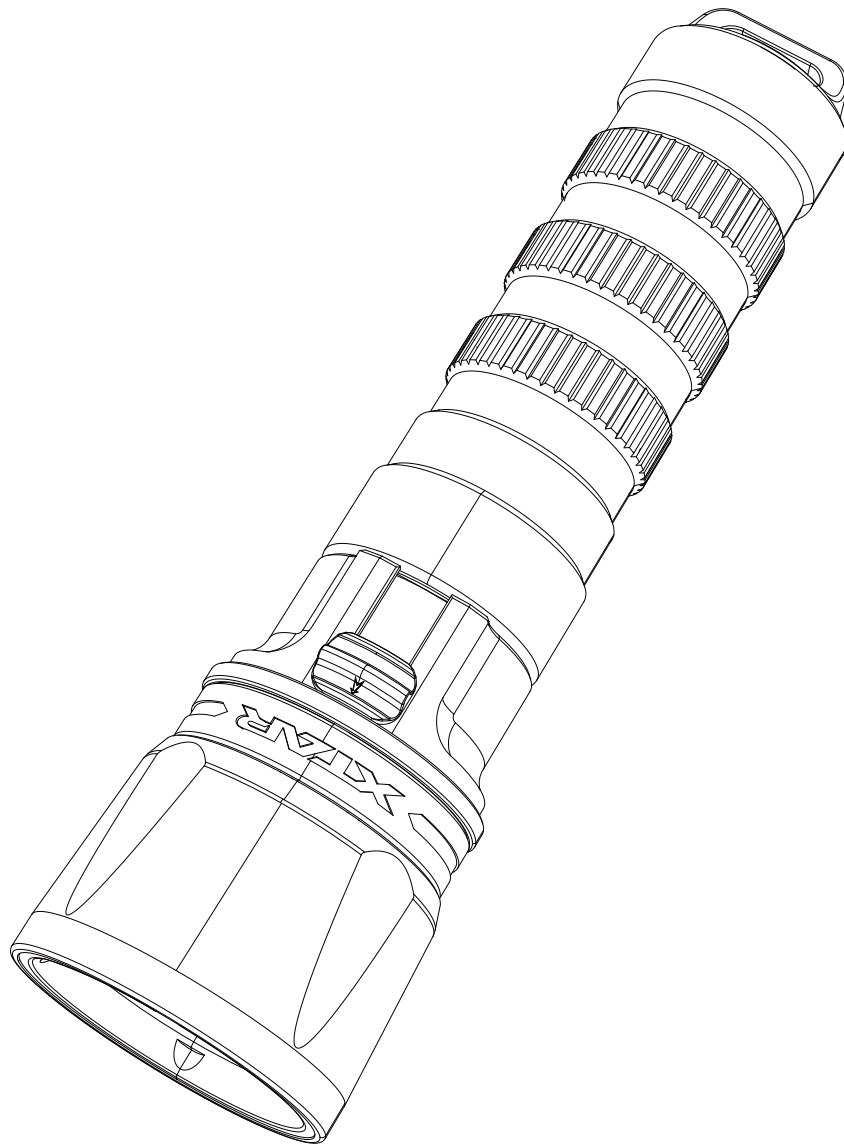





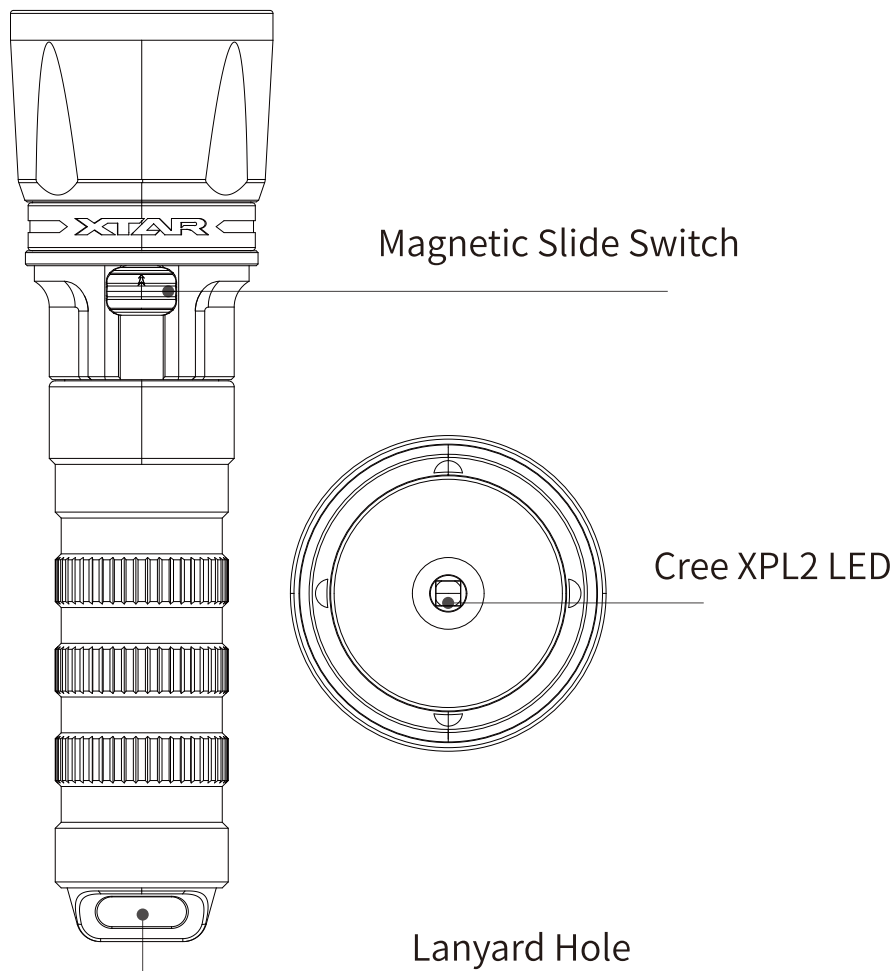



Introduction

DS1 is a quality dive light for recreational diving and spearfishing, it has a sensible magnetic slide switch that offers one-hand operation accessible anytime, anywhere. With its simplicity of operation, users may easily adjust brightness levels. Its knurling body enhances anti-skid performance. It weighs 177g only.



Parameter

ANSI	High - Low
	1000lm-30lm
	2.5hrs-49hrs
	$\Phi 44\text{mm}(\text{head}) \times \Phi 29\text{mm}(\text{body})$ $\times 156\text{mm}(\text{length})$
	282m
	20032cd
	1.5m
	IPX8(Underwater 100m)
	177g

Notes:

1. Above-mentioned parameters (tested by using XTAR 1 x 21700 4900mAh) are approximate and may differ depending on battery and environment.

2. Working Voltage: 2.75-4.2V.

Operation

1. Install battery.

Unscrew tail cap, and install the battery with

positive pole (+) towards head.

2. Choose lightness.

Push switch forward or backward to adjust brightness.

Tips

1. Please make sure positive pole (+) towards the head.

2. Considering flashlight consumes power when it is off, please unscrew tail and move switch to bottom.

3. To avoid LED flashes, and please move the switch gently.

4. Do not wipe the battery with strong corrosive substance.

5. To prolong the lifespan of your dive light, please take out the battery when not using it.

6. Rinse the dive light after use. Repeatedly press push the switch while washing to make sure that seawater inside is drained. Then put it back after dried.

7. The waterproof switch and o-ring at the body needs to stay lubricated to ensure normal use of the dive light. Please replenish lubricant regularly. Recommended to use XTAR lubricant.

8. Flashlight fails to operate.

Possible reasons	Solutions
Battery is exhausted or not compatible	Change battery
Battery is installed incorrectly	Make sure the positive pole (+) towards the head.
Poor contact	1. Clean the contact surface with alcohol. 2. Tighten the head and tail cap.

9. For more and updated information, please visit www.xtar.cc

After-sales

Please provide warranty number to our distributor to get after-sales service.

- 15 days free replacement.
- 24 months free repair. If problem developed is beyond 24 months, we will offer free repair service but charge for parts used. The distributor will inform you material fee or related freight if any before repair.
- Lifetime technical support.

Note:

1. Damage caused by misuse or intentional is not covered by the warranty.
2. Warranty number (9-13 digits) can be found on the package or product.

Global After-sales Email: service@xtar.cc

Anti-fake inquiry

1. Scratch the anti-counterfeiting label on the package to get 18-digit number.
2. Input the number into the query page on www.xtar.cc (Contact Us - Anti-fake).



**Warning: Do not direct the light
towards the eyes.
Serious injury or blindness may
occur by misuse.**

XTAR[®]

Shenzhen XTAR Electronics Co., Ltd
Address: 5th Floor, No.77 Xinhe Rd, Shangmugu,
Pinghu Area, Longgang District, Shenzhen , Guangdong, China
Tel:+86-755-25507076 Fax:+86-755-25507076
Website:www.xtar.cc Email:info@xtar.cc
Zip Code: 518111

Made in China



V1

XTAR[®]

DS1

磁控滑动开关潜水手电筒

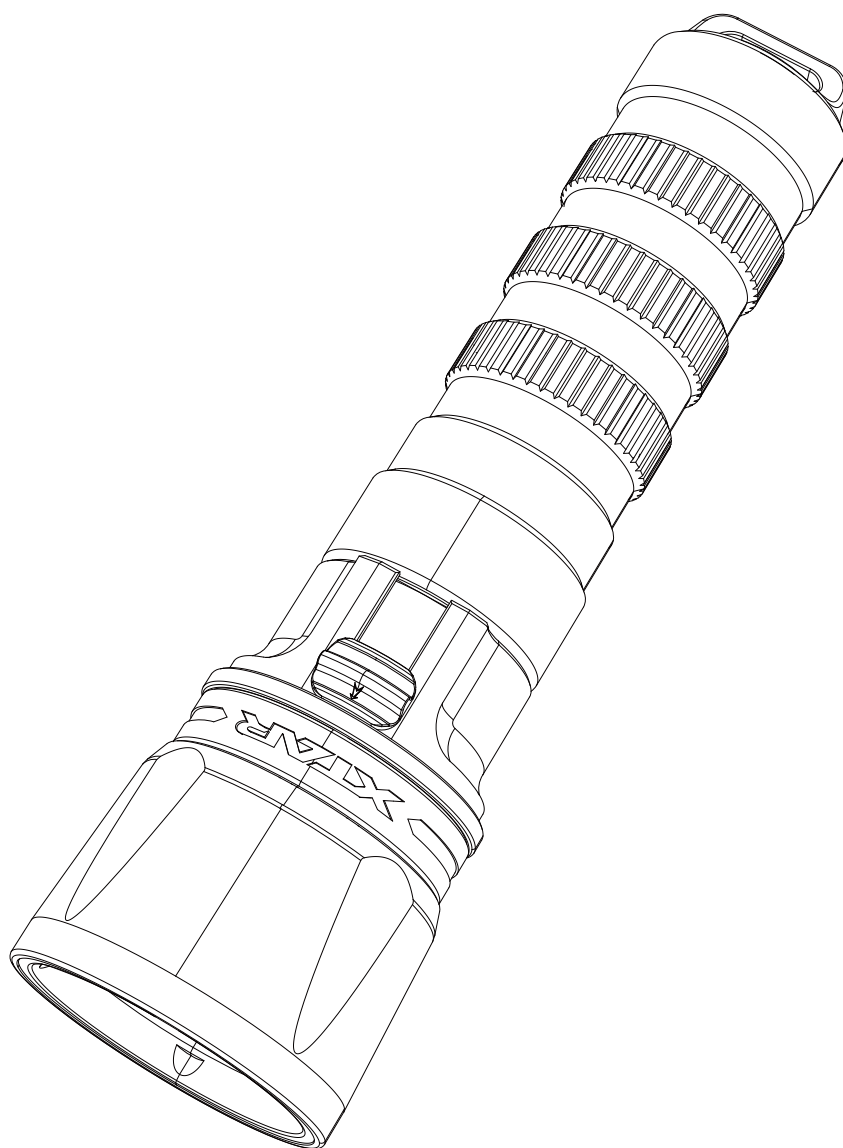

产品介绍

DS1是一款可单手操作的带有磁控滑动开关的潜水手电，此款手电前端配有磁控滑动开关，用户可单手轻松滑动磁控开关来调节亮度档位。滚花筒身增强了防滑性能，仅重177克，是您潜水和钓鱼的绝佳选择。

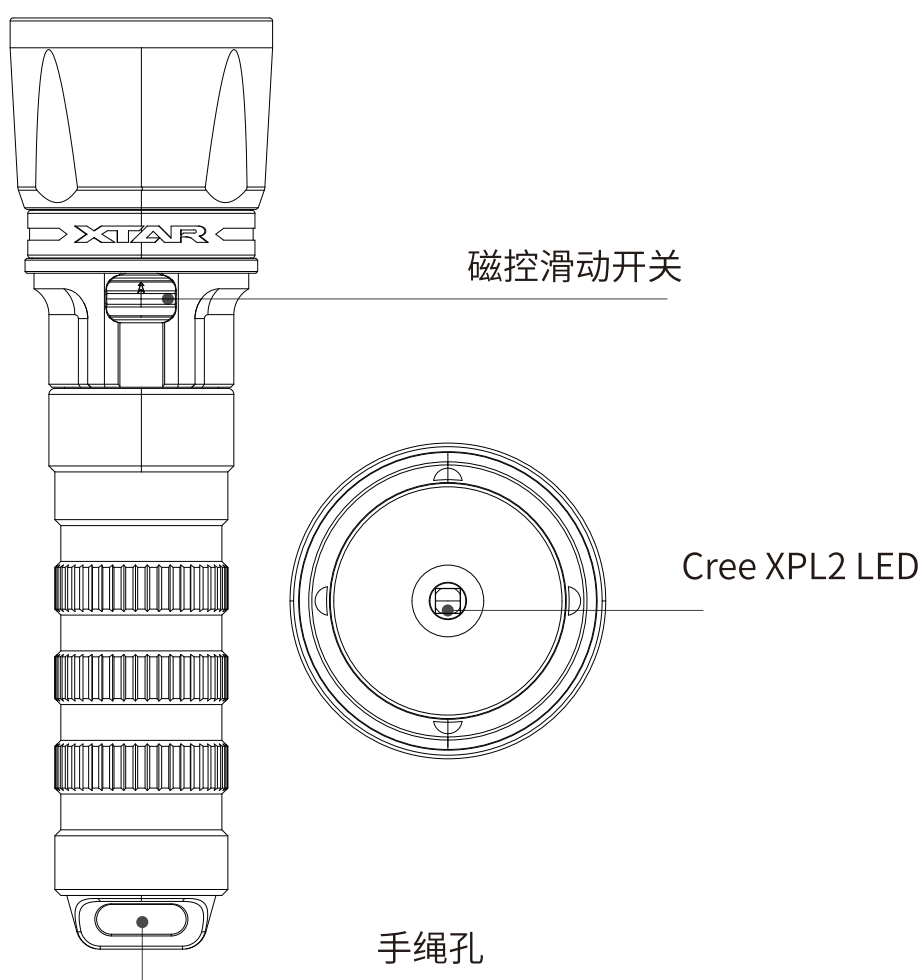

参数表

ANSI	高亮档-低亮档
	1000lm-30lm
	2.5hrs-49hrs
	Φ44mm(头部) × Φ29mm(筒身) × 156mm(长度)
	282m
	20032cd
	1.5m
	IPX8(水下100m)
	177g

注意:

1. 以上参数 (是由爱克斯达 1 x 21700 4900mAh 的电池测试得出) 均为近似值, 可能会随着电池和使用环境而发生变化。

2. 工作电压: 2.75-4.2V.

操作

1. 电池安装

拧开手电筒尾盖, 将电池正极 (+) 朝头部安装。

2. 选择亮度

向前或向后拨动开关调整亮度。

温馨提示

1. 请确保正极 (+) 朝向头部。
2. 考虑到手电筒关闭时会消耗电量, 请拧开尾盖并将开关拨至底部。
3. 为避免可能导致的LED闪烁, 请平缓拨动开关。
4. 请勿用强腐蚀性物质擦拭电池。
5. 不使用手电时, 请及时取出电池;
6. 潜水后, 为避免海水腐蚀水电筒, 请及时用清水冲洗。冲洗时, 要反复推动开关, 确保把开关里面的海水排出, 然后晾干保存;
7. 为保证手电筒的正常使用, 请定期给开关和防水圈补润滑, 推荐使用XTAR专售润滑油。

8. 手电筒不工作

可能原因	解决办法
电池电量用完或不兼容	更换电池
电池安装不当	请确保电池正极 (+) 朝向手电头部
接触不良	1.用酒精清洁电池的接触表面 2.拧紧手电头盖和尾盖

9. 了解更多更新的信息, 请访问www.xtar.cc

售后服务

请向经销商提供保修编号以获得售后服务。

- 15天免费换新。
- 2年内免费保修。若问题发生在2年之后,我们将提供免费维修服务,但收取所用零件的费用。经销商会在维修前通知您材料费或相关运费。
- 终身技术支持。

注意:

- 1.因用户使用、保管不当而产生的故障不享有免费包换和保修。
2. 保修编号(9-13位)可在包装或产品上找到。

售后服务邮箱: **service@xtar.cc**

防伪查询

1. 刮开包装上的防伪标签, 得到18位数字。
2. 将该号码输入www.xtar.cn上的查询页面 (联系我们 - 防伪查询)。



**警告: 请不要将手电直射眼睛,
否则可能因误用而造成
严重伤害或失明。**

XTAR[®]

深圳市爱克斯达电子有限公司
地址:广东省深圳市龙岗区平湖街道上木古社区
新河路77号5楼
邮编:518111
官网:www.xtar.cn
邮箱:info@xtar.cc
电话:(+86) 755-25507076
传真:(+86) 755-25507076

中国制造



V1